

| SPECIFICATIONS                 |   |
|--------------------------------|---|
| CONTACT CARRIER MATERIAL/COLOR | TPU/BLUE-GRAY                                       |
| MOLDED HEAD MATERIAL/COLOR     | TPU/BLUE-GRAY                                       |
| CONTACT MATERIAL/PLATING       | BRASS/GOLD  |
| COUPLING NUT MATERIAL/PLATING  | BRASS/NICKEL  |
| RATED CURRENT [A]              | 7.0 A   |
| RATED VOLTAGE [V]              | 300 V   |
| OUTER JACKET MATERIAL/COLOR    | TPU/GRAY  |
| CONDUCTOR INSULATION MATERIAL  | FOAMED HDPE (DATA), PVC (POWER)                     |
| NUMBER OF CONDUCTORS [AWG]     | 2x17 AWG, 2x20 AWG, 20 AWG DRAIN                    |
| SHIELDING                      | FOIL (AROUND PAIRS), ALUM./POLYESTER FOIL (OVERALL) |
| TEMPERATURE RATING             | -40°C to +80°C (-40°F to +176°F)                    |
| PROTECTION CLASS               | NEMA 1,3,4,6P,12 & IECIP67, IP68,IP69,IP69K         |

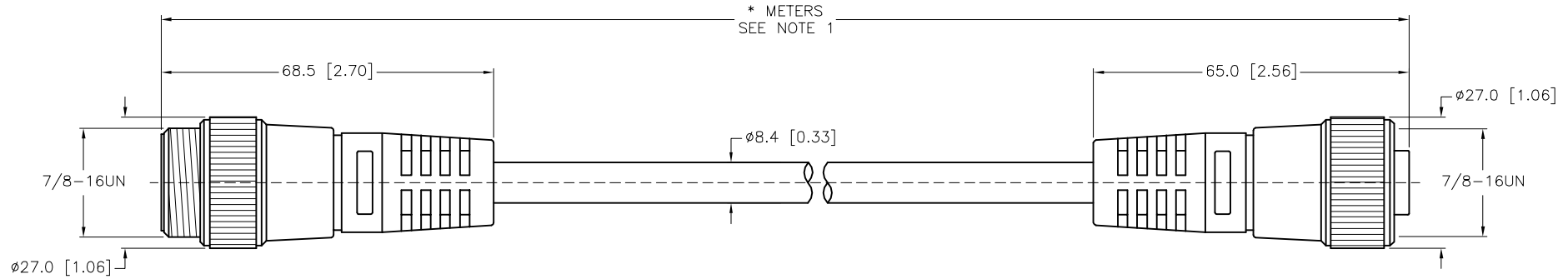

| CABLE LENGTH | TOLERANCE*  |
|--------------|---|
| ALL LENGTHS  | + 4% (OR 50mm) OF LENGTH<br>- 0% (OR 0mm) OF LENGTH<br>WHICHEVER IS GREATER |
| STRIP LENGTH | TOLERANCE*  |
| 0-7mm        | ±0.5mm  |
| 8-29mm       | ±1.0mm  |
| 30-49mm      | ±2.0mm  |
| 50-69mm      | ±3.0mm  |
| 70-100mm     | ±4.0mm  |
| OVER 100mm   | ±5.0mm  |

\* UNLESS OTHERWISE SPECIFIED

**SOURCE DRAWING - FOR REFERENCE ONLY**

NOTES:  
1. "\*" INDICATES CABLE LENGTH IN METERS. CONTACT TURCK TO ORDER SPECIFIC LENGTHS.

|  |   |  |                    |  |         |
|--|---|--|--------------------|--|---------|
| RELATED DOCUMENTS<br>1.<br>2.<br>3.<br>4.    | 3RD ANGLE PROJECTION<br>  | THIS DRAWING IS CONFIDENTIAL AND THE PROPERTY OF TURCK INC. USE OF THIS DOCUMENT WITHOUT WRITTEN PERMISSION IS PROHIBITED. |                    | 3000 CAMPUS DRIVE<br>MINNEAPOLIS, MN 55441<br>1-800-544-7769<br>(763) 553-7300<br>(763) 553-0708 fax<br>www.turck.us |         |
|  |   | MATERIAL   | DRFT CBM<br>APVD   | DATE 12/03/01<br>SCALE 1=1.3   |         |
| FINISH                                       | ALL DIMENSIONS DISPLAYED ON THIS DRAWING ARE FOR REFERENCE ONLY<br><br>CONTACT TURCK FOR MORE INFORMATION | UNIT OF MEASUREMENT<br><b>MILLIMETER [ INCH ]</b>  |                    | DESCRIPTION<br>RSM RKM 5723-*M   |         |
| I UPDATE PROTECTION CLASS<br>REV DESCRIPTION |   | CBM 04/13/21 76628<br>BY DATE ECO NO.  | IDENTIFICATION NO. |  | REV<br> |